

Tandem Vibratory Roller

BW120AD-4



EARTHWORKS						
# passes	rolling speed	area coverage sq yd/hr	"productivity in cu yd/hr by lift thickness, 100% efficiency"			
	(mph)		4 inches	6 inches	8 inches	12 inches
2	4.77	5504	612	919	1225	1837
3	4.77	3669	408	612	817	1225
4	4.77	2752	306	459	612	919
5	4.77	2201	245	367	490	735

ASPHALTIC CONCRETE (material weight 140 lb/cu ft)						
# passes	rolling speed	area coverage sq yd/hr	"productivity in tons/hr by lift thickness, 100% efficiency"			
	(mph)		1.5 inches	2 inches	2.5 inches	3 inches
2	4.77	5504	434	579	723	868
3	4.77	3669	289	386	482	579
4	4.77	2752	217	289	362	434
5	4.77	2201	174	231	289	347
6	4.77	1835	145	193	241	289

Note: Repeat number of passes over the same area is required to achieve specified compaction efficiency/density. Successive passes over same area results in reduced area coverage and productivity. Rolling speed selected provides impact spacing of a minimum 10 impacts per foot at high vibration frequency setting. Actual compaction efficiency is determined by job conditions.

BW120AD-4



■ Dash 4 Series – Setting the standard for excellence...

The next generation BW120AD-4, establishes the “benchmark” for all other competitive rollers to measure up to. Combining compact size and high maneuverability with heavy tandem roller features the new BW120AD-4 delivers outstanding performance.

This new model from BOMAG features more performance, increased productivity, improved safety details and unsurpassed operator comfort. Slanted drum support legs with high curb clearance, afford unobstructed

view of the drum edges, minimal lateral offset and the ability to work closely to obstructions and in confined areas.

The two (2) position throttle detail offers dual vibration frequencies, providing maximum compaction results on a wide range of applications and material types.

■ Applications:

- Granular sub-base compaction
- Walkways, bicycle and cart paths
- Driveways and Parking lots
- Road rehabilitation and patching



BW120AD-4 shown with optional folding ROPS.



Ergonomically engineered operator's platform providing optimum comfort and maximum productivity.

■ Handling is Easier & Safer:

- New, slanted drum support legs provide improved visibility of the drum edges, minimizing the possibility of damage when working in confined areas. High curb clearance allows working close to obstructions.
- Central, lifting point, makes strategic handling and loading of the BW120AD-4 easier with little risk of body damage.
- The standard sliding seat arrangement provides improved drum edge and overall side visibility for safer and more comfortable operation.
- The travel control lever and two (2) position throttle control are positioned for easy access and safe operation.
- Fully hydrostatic travel design offers smooth yet responsive control.
- Standard FOPS/ROPS with safety seat belts offer additional operator safety.

Light duty tandem models provide maximum versatility and productivity

■ Achieve Maximum Productivity:

- The BW120AD-4 has two (2) vibration frequencies for optimized compaction on a wider range of material types.
- Vibration can be selectively shut-off on the rear drum to prevent over compaction and material damage to sensitive material types and thin lift applications.
- Large diameter drums minimize pushing and cracking of mat surface, delivering a high quality finish.
- High curb clearance and minimal lateral overhang allow for working close to obstructions, minimizing handwork.
- Standard dual drum scrapers (2 per drum) ensure clean drums in either forward or reverse travel direction.
- Drum amplitude and frequency are optimized to provide high performance and maximum productivity on a wide range of applications.
- Water spray system automatically cancels in neutral travel position, extending tank life.

■ Less Service & Maintenance:

The purchase price is always important, But more importantly are the operating costs.

Check these features:

- Drum vibration bearings and travel system SAHR brakes are maintenance free.
- Drum shell wrapper thickness and head plates are designed to provide maximum strength for long life and durability.
- Bolt-on oscillating, articulation joint provides long life and simplifies repairs.
- Wide opening, lockable, composite engine cover provides easy service access and minimizes possible underhood vandalism.
- The BOMAG hydraulic oil filtration system extends servicing intervals to 2000 hours.
- Daily maintenance check points are quickly completed with easy access, visual indicators for hydraulic oil level, oil filter and air filter.
- Hydraulic test ports are easily accessible for simplified troubleshooting.
- Vandal protected instrument panel detail insures against on-site electrical problems.
- Water spray pump and filter are easily accessed in a centralized location and sprinkler nozzles are quick disconnect design for easy cleaning when required.

Featuring...



Wind protected, quick-disconnect spray nozzles with dual scrapers per drum.



Bolt-on center-joint, with standard crab steer off-set, provides long life and ease of repair.

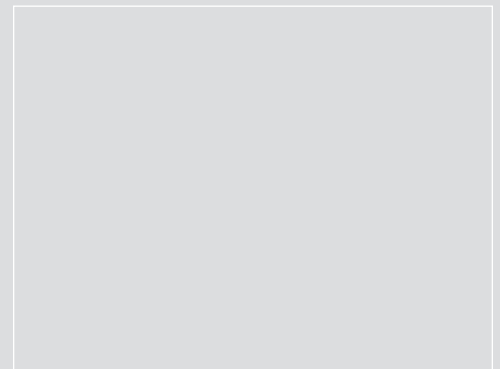

Easy access engine and drive components for simplified servicing

With these features and many more, it's easy to see why this model maintains a high residual value while delivering lower lifetime operating costs.

Technical Specifications

BW120AD-4

Shipping dimensions

in cubic feet (m ³)	without/with ROPS	
BW120AD-4	200.3 (5.67)	277.1 (7.85)

Standard Equipment

- Oscillating articulating center joint
- 2 scrapers per drum
- Suspended operator's platform
- Plastic water tank
- Hour meter
- Lockable engine cover
- Crab walk (1.6 in / 40 mm)
- Lockable anti-vandal dashboard protection
- Transport lashing and lifting points front/rear
- Emergency stop button
- Vibration cut-off, rear drum
- Back-up alarm
- Water level indicator
- Fuel level indicator
- Pressurized water sprinkler system
- Laterally sliding seat
- FOPS/ROPS with safety belts

Optional Equipment

- Working lights front/rear
- Seat with contact switch
- Edge cutter
- Indicator and hazard lights
- Rotary beacon
- Biodegradable hydraulic oil
- Special paint
- Tool kit
- Double travel lever (Sliding Seat)
- Foldable ROPS with seat belts
- ROPS with seat belts
- Single point lifting device

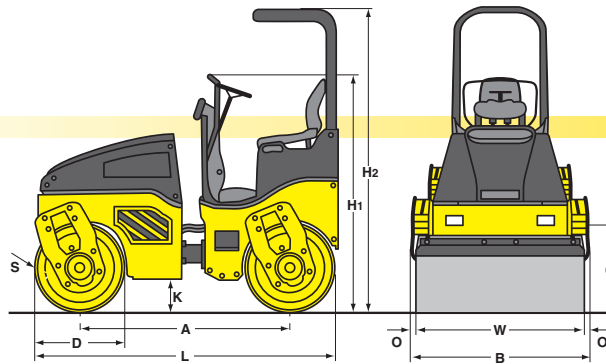

Dimensions in inches (mm)

	A	B	C	D	H ₁	H ₂	K	L	O	S	W
BW120AD-4	68.0	50.23	18.7	27.6	70.9	98.0	9.8	97.2	1.5	0.5	47.2
	(1728)	(1276)	(475)	(700)	(1800)	(2490)	(250)	(2470)	(38)	(13)	(1200)

Technical data

Weights

Basic Weight with ROPS	lbs (kg)	5236 (2375)
Operating Weight	lbs (kg)	5732 (2600)
Average axle load	lbs (kg)	2866 (1300)
Average static linear load CECE	pli (kg/cm)	60.7 (10.8)

Dimensions

Length with ROPS	in (mm)	97.2 (2470)
Track Radius, inner	in (mm)	103.1 (2620)
Dimensions		see sketch

Driving Characteristics (depending on site conditions)

Speed (with vibration)	mph (kmph)	0-4.0 (0-6.5)
Speed (for transport)	mph (kmph)	0-7.5 (0-12)
Max. gradeability without/with vibration	%	40/30

Drive

Engine manufacturer		Kubota
Type		D 1703 MDI
Cooling		Water
Number of cylinders		3
Performance ISO 9249 (max)	hp (kW)	34.3 (25.2)
Speed (max)	rpm	2700
Performance SAE J1349 (max)	hp (kW)	33.8 (25.2)
Speed (max)	rpm	2700
Throttle position 1	rpm	2200
Throttle position 2	rpm	2600
Electric Equipment	V	12

Brakes

Service brake	hydrostatic
Parking brake	SAHR

Steering

Steering system	oscillating, articulating
Steering method	hydrostatic
Steering angle +/-	30
Oscillating angle +/-	12

Vibratory system

Vibrating drum	f + r	
Drive system	hydrostatic	
Frequency	vpm (Hz)	3300/4200 (55/70)
Amplitude	in (mm)	0.020 (0.52)
Centrifugal force (each drum)	lbs (kN)	6300/10125 (28/45)

Water Spray System

Type of water spray system	pressurized
----------------------------	-------------

Capacities

Fuel	gal (l)	10.6 (40)
Water	gal (l)	58.1 (220)

Technical modifications reserved. Machines may be shown with options.

B396H-1909 4M607JMTTP